

Gas Mixer

DATA SHEET

Description

The gas mixer is an indispensable component of the fuel system. Whilst the throttle valve controls the quantity of the mixture, the mixing unit takes care for quality of the mixture.

HEINZMANN mixers provide a very homogeneous air and gas mixture and an optimal Air to Fuel Ratio (AFR) over the entire speed and load range of the engine. HEINZMANN also can supply the remaining components of the fuel system such as main adjusting screw, zero pressure regulator, throttle valve, speed and load control, AFR controls for stoichiometric as well as for lean burn, adaptors, levers etc..

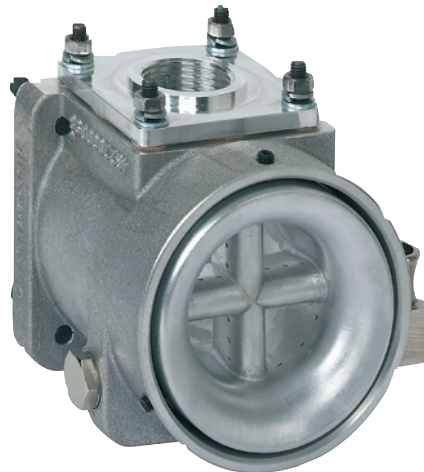

Application range

Type	Gas Engine Output Range in kW *			
	Stoichiometric		Lean burn **	
	min.	max.	min.	max.
Size 50	35	125	25	85
Size 100	70	250	50	170
Size 140	140	500	100	340
Size 200	330	1200	230	840
Size 300	750	2250	500	1500

* Power at draw-through carburetion. In blow-through application the output will be 50 % to 150 % higher, dependent on the boost pressure

** Power at an Air to Fuel Ratio of about 1,6

Technical data

- ➔ Operating temperature: -20 to +150 °C
- ➔ Max. boost pressure: 4 bar abs.

Features

Mixes gas and air to a very homogenous mixture

Automatic metering of the gas at any air flow according to Bernoulli's law

Cost effective and maintenance-free fuel system component without moving parts

Very low pressure drop due to the almost ideal shaped Venturi insert

Applicable for a wide range of gasses (e.g. natural gas, landfill gas, bio gas, propane)

Adaptable matching throttle valve or hose connector

Suitable for naturally aspirated and turbo charged engines

The carburetors can be configured as draw-through as well as blow-through

The carburettor models are also available for dual gas, EGR and low calorific gasses

Supplied with balance line connector in order to compensate for air filter restriction

For corrosive gases the components are also available in anti-corrosive versions

The mixer insert can be configured and removed by the customer

Dimensions

Size 50

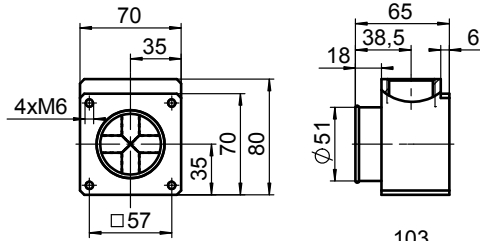

Size 100

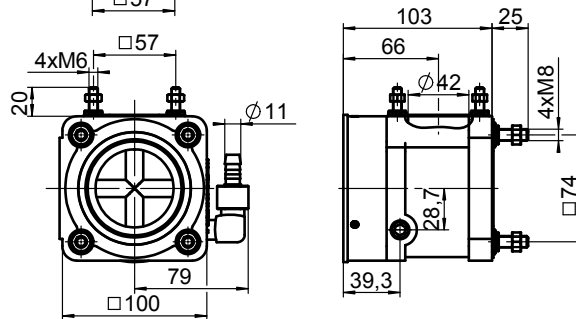

Size 140

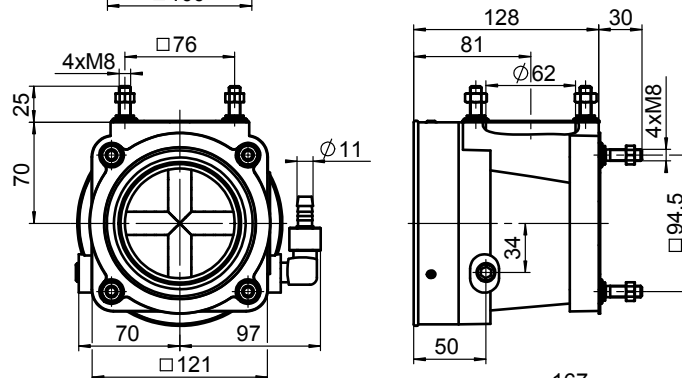

Size 200

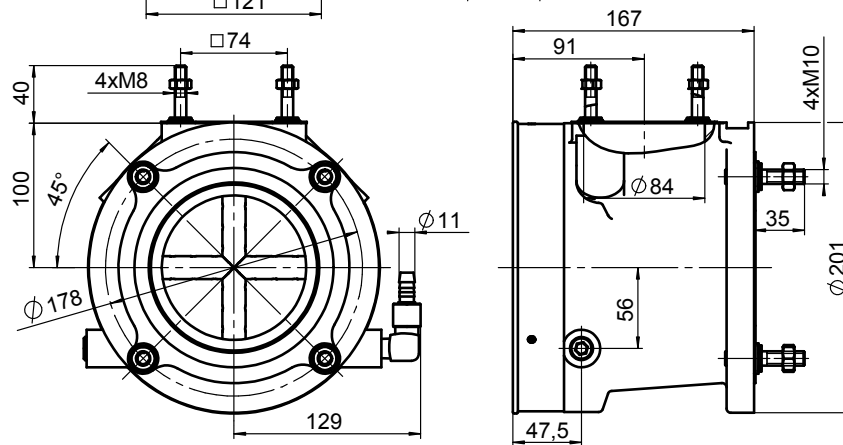

Dimensions for
size 300 on request

Certificates

ATEX  II 2 G c II

For further information please see the relevant manual:

AFR 05 001-e 10-08 KRONOS 10.pdf

Subject to alterations. ©HEINZMANN GmbH & Co. KG, 2009