

MODEL 512

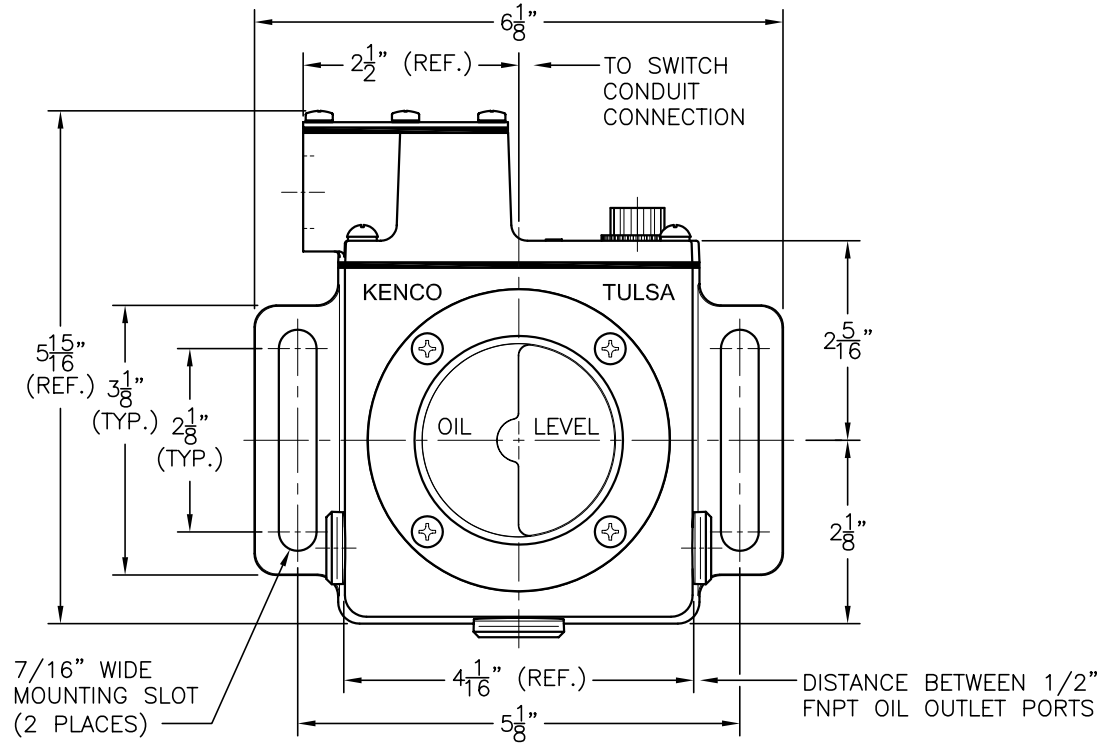
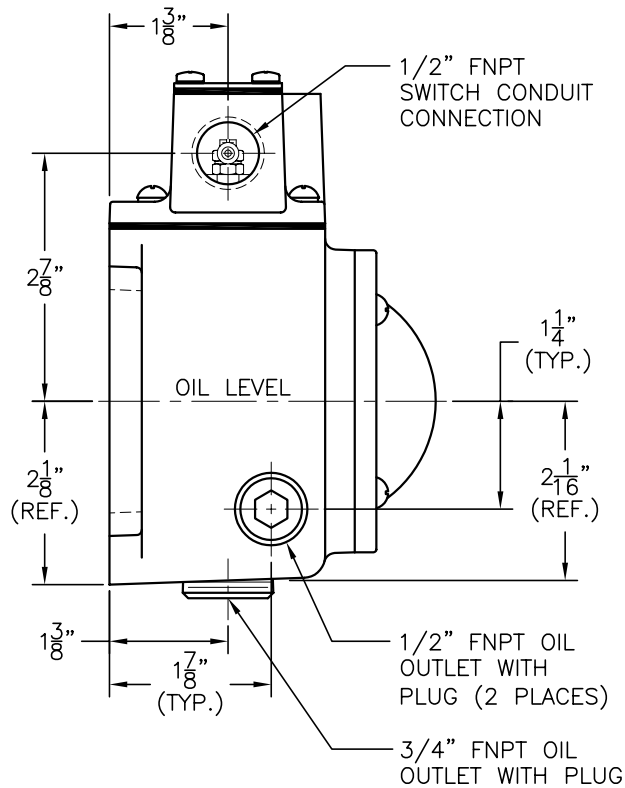
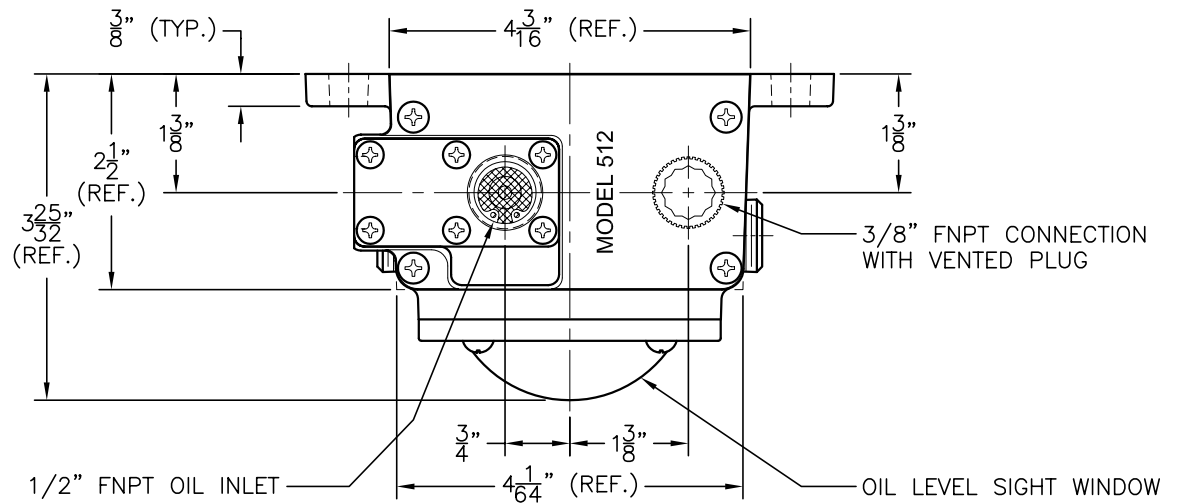

DIMENSIONS ARE FOR REFERENCE PURPOSES ONLY AND ARE SUBJECT TO CHANGE AT ANY TIME WITHOUT NOTICE
 COPYRIGHT © 2003-KENCO INTERNATIONAL, INC.-ALL RIGHTS RESERVED

REV.	DATE	BY	ECN	EXPLANATION:
A	04-09-98	DW	N/A	REDRAWN AND UPDATED
B	05-10-01	RDM	N/A	ADDED 13/32" WIDE SLOTS TO HOUSING
C	01-30-02	RDM	N/A	REDRAWN AND UPDATED FOR NEW CASTINGS; ADDED 1/2" FNPT OIL OUTLET CONNECTIONS
D	06-06-02	RDM	N/A	2-1/2" WAS 2-17/32"; 3-25/32" WAS 3-13/16"
E	05-06-04	RDM	N/A	5-15/16" (REF.) WAS 5-31/32" (REF.)

KENCO ENGINEERING COMPANY
 TULSA, OKLAHOMA

CONTROLLER, OIL LEVEL MODEL 512
 (OUTLINE DRAWING)

DATE: 03-11-85 SHEET: 1 OF 1 DRAWING NUMBER
 DRN. BY: JC CHKD. BY: C-4238
 SCALE: 7/8"=1" REVISION: E